

## TECHNOLOGY



### Quick fit

Provides instant and secure wiring and connections housed in an IP66-rated enclosure for robust protection against dust and water.



### Smart fit

Enhance Tria Pole by incorporating advanced features, making it suitable for modern, connected environments.

## Tria L



### Qualicoat Seaside Class Powder Coat

Enhanced powder coating for aluminum, specifically formulated for superior durability and optimal performance in marine environments, lasting for over 10 years.

# Tria L

Specification Sheet

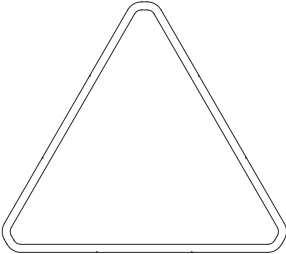

EN-40  
IP54/IP66

## POLE FEATURES

### Design and Application

- Urban main streets
- Commercial areas
- Larger squares
- Parking areas

### Mechanical details

- IK10
- IP54 rating of the pole
- IP66 rating at Quick Connect interface
- Extruded aluminum body
- Triple surface protected with anodised base layer, primer coat and Qualicoat Sea-side Class powder coat top layer – rated C5 marine, 10+ years performance
- Supplied with oil and water resistant cable

### Electrical details

- 230VAC Input

### Controls

- DALI

### Integrated modability systems:

- Quick Fit
- Smart Fit

### Sustainability

- Recyclable material
- Repairable

### Links & Downloads

- [Installation manual - Pole](#)
- [Installation manual - Anchoring](#)
- CAD files

# Tria L

## ORDERING INFORMATION

<b>MODEL</b>	
TRL	
<b>HEIGHT</b>	
70	• 70 - 7000mm
75	• 75 - 7500mm
80	• 80 - 8000mm
85	• 85 - 8500mm
90	• 90 - 9000mm
<b>FINISH COLOR</b>	
W	• W - RAL9003 Structure (Signal White)
S	• S - RAL7044 Structure (Silky Grey)
A	• A - RAL7016 Structure (Antracite Grey)
B	• B - RAL9005 Structure (Jet Black)
D	• D - RAL1015 Structure (Desert Sand)
G	• G - RAL6002 Structure (Leaf Green)
C	• C - Custom Structure Color
<b>ANCHOR TYPE</b>	
C0	• C0 - Concrete Anchor
C1	• C1 - Concrete Anchor with PS 500W
C2	• C2 - Concrete Anchor with PS 650W
U0	• U0 - Utility Vault
U1	• U1 - Utility Vault with PS 500W
U2	• U2 - Utility Vault with PS 650W
<b>CONTROL</b>	
D	• D- Dali Operation

# Tria L

## MANDATORY ACCESSORIES

### Installation options

<b>INSTALLATION</b>	
COATRL	• COATRL - Concrete Anchor
UVOATRL	• UVOATRL - Utility Vault

## OPTIONAL ACCESSORIES

### Various

<b>VARIOUS</b>	
A0	• A0 - Electrical Safety
B0	• B0 - User-Accessible Options
C0	• C0 - Wireless / Automatic Control
D0	• D0 - Smart Sensors
E0	• E0 - Communication
ST	• ST - Static signage
EB	• EB - Expression backlight
CC	• CC - Connectors
RT	• RT - Cover removal tool
TRLPC	• TRLPC - Tria L pole cover
105790	• 105790 - Fuse box

Consult you regional sale representativ for further deatails

# Tria L

## INSTALLATION DETAILS

### Pole height

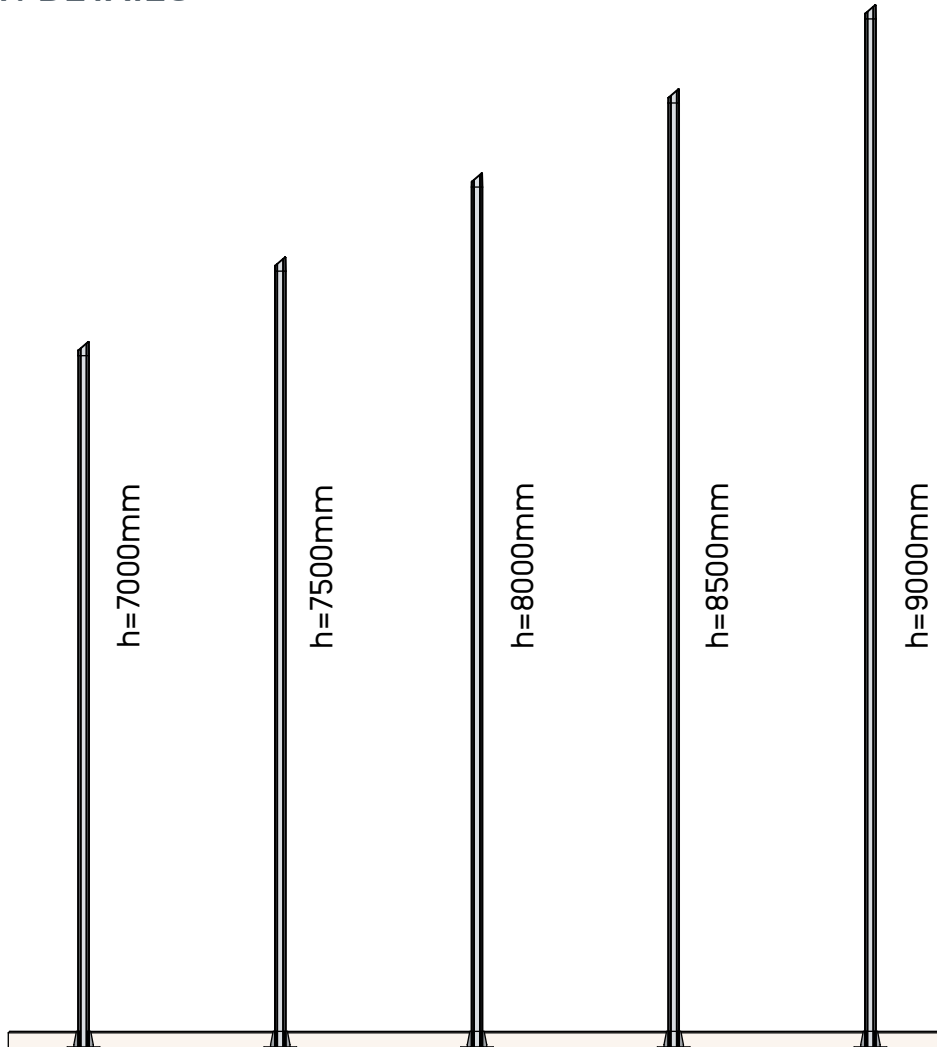

### Profile details

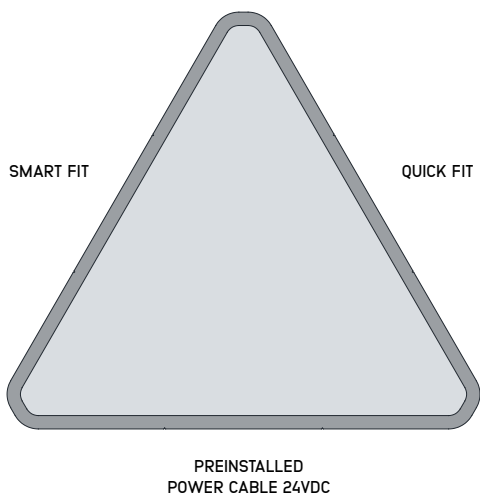

IP-rated tracklight functionality is provided, ensuring reliable performance in demanding environments. Fixtures can be repositioned along the vertical profiles as needed, offering flexibility during and after installation. The profile is protected against tampering, and full system modularity is preserved even when the site installation is still in progress.

# Tria L

## QUICK FIT INSTALLATION

Step 1

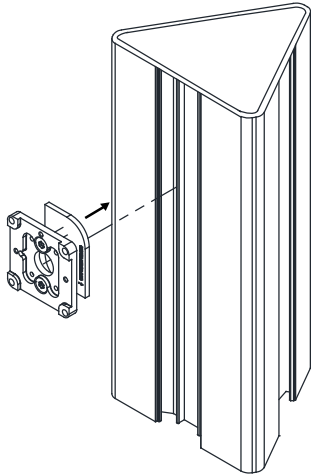

Step 2

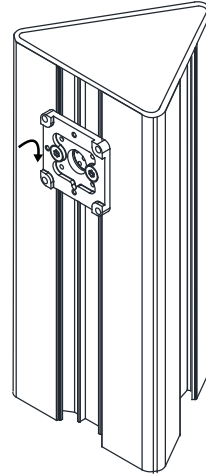

Step 3

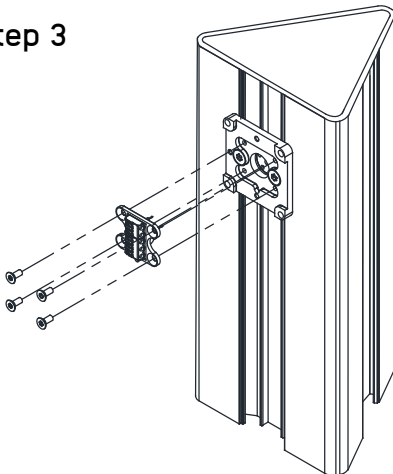

Step 4

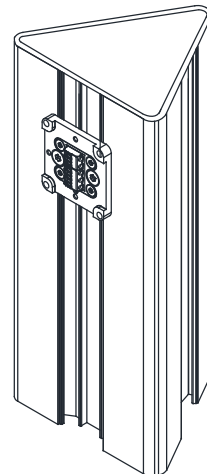

### Quick Fit Installation

Designed for efficiency and flexibility, the system includes an IP66-rated instant wiring and connection method and is compatible with control protocols. Its streamlined installation process ensures quick deployment, while secure connections enhance reliability. The modular design makes it easy to expand with additional fixtures or adjust fixture positions as needed.

# Tria L

## INSTALLATION DETAILS

### Concrete Anchor

Standard pole system installation on a concrete foundation, providing reliable and long-lasting stability, even in demanding conditions. With this anchoring method, the power supply unit is placed within the pole structure.

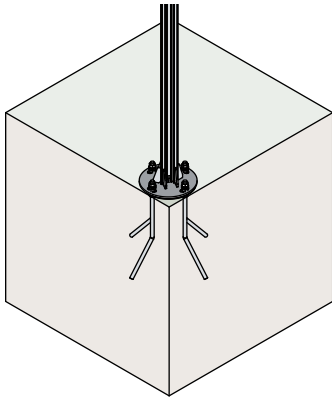

### Utility Vault

The Utility Vault serves as a pre-installed access point for pole-mounted installations, functioning like an underground junction box. It enables simplified wiring by allowing the main power cable—running from the distribution cabinet—to terminate at the vault. From there, separate cables branch out to nearby luminaires. Depending on the luminaire type, each cable may serve one or multiple fixtures. LED transformers are housed directly within the Tria pole structure, streamlining installation and maintenance.

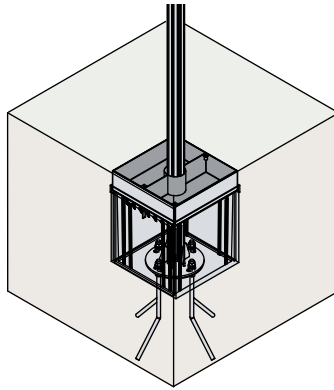

# Tria L

## OPTIONAL ACCESSORIES

### Pole Cover

This replacement cover for an already installed pole system is designed to maintain both safety and functionality. It acts as a durable physical barrier between the pole's internal cabling system and the end user, ensuring reliable protection during operation and maintenance. In addition to its safety role, the cover can also accommodate communication-related components, making it suitable for integrated or smart pole applications.

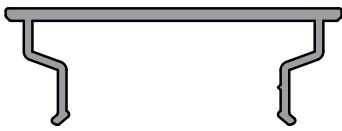

### Electrical Safety

Electrical safety functionality can be integrated to ensure reliable operation and protection under variable electrical conditions. Internal components can be safeguarded against electrical faults, voltage fluctuations, and transient events, while stable power conversion and distribution can be maintained. The availability and implementation of these features are subject to project requirements and should be confirmed in consultation with a sales representative.



### User-Accessible options

User-accessible functionality can be integrated to provide on-site power access and charging capabilities for connected devices and equipment. Access points may be protected against unauthorized use and mechanical damage through dedicated protective elements, ensuring safe and reliable operation in public environments. The availability, configuration, and implementation of these features are subject to project requirements and should be confirmed in consultation with a sales representative.



### Wireless / Automated Control

Advanced control capabilities may be incorporated to support remote management, adaptive system responses, and intelligent operational behavior. Automatic regulation can be applied based on environmental conditions, detected activity, or predefined schedules, while output levels may be dynamically adjusted to optimize energy efficiency and system performance. The scope and configuration of these features are defined by project requirements and should be confirmed in consultation with a sales representative.



### Smart Sensors

Integrated sensing capabilities can be incorporated to enable real-time monitoring of environmental conditions, user presence, system orientation, and surrounding activity. Collected data may be used to support adaptive system behavior, safety-related functions, usage analytics, and responsive control strategies. Protective measures and secure integration can be applied to ensure reliable operation in public environments. Sensor availability, configuration, and functional scope are defined by project requirements and should be confirmed in consultation with a sales representative.

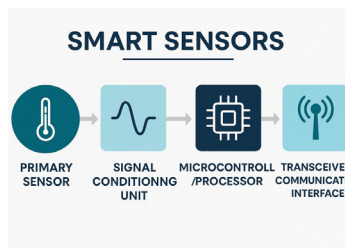

### Communications

Communication capabilities may be integrated to enable reliable data exchange, remote connectivity, and system-level interaction with external networks or platforms. Data transmission, device management, and software updates can be supported through wired or wireless interfaces, while local processing and cloud-based integration may be employed to enhance system responsiveness and scalability. Interface availability, communication architecture, and functional scope are defined by project requirements and should be confirmed in consultation with a sales representative.

